

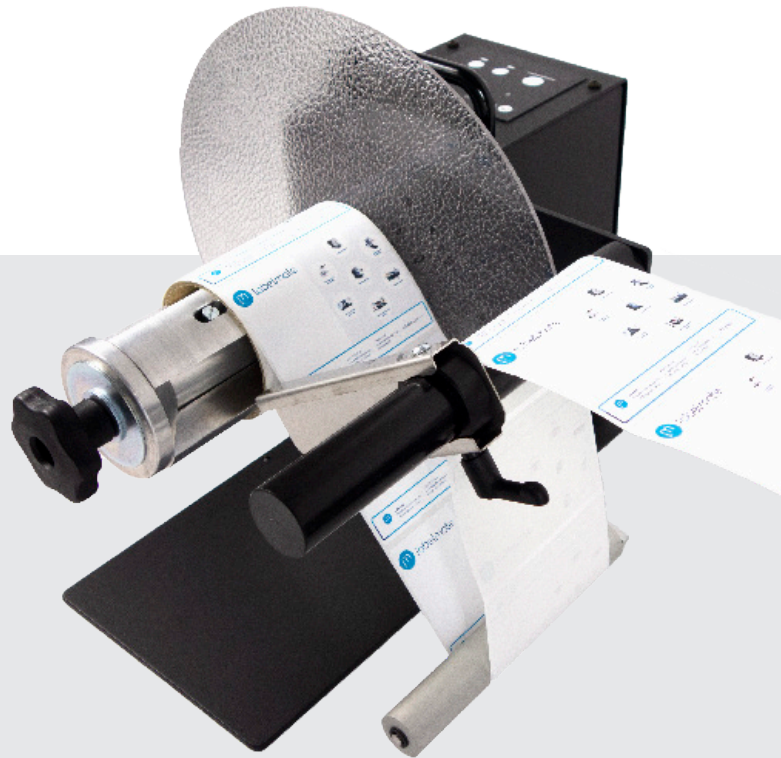

labelmate

THE WORLD'S LEADING MANUFACTURER OF LABEL DISPENSERS, REWINDERS, UNWINDERS, SLITTERS & COUNTING SOLUTIONS



WATCH THE VIDEO



UNI-CAT
USER MANUAL

labelmate.com

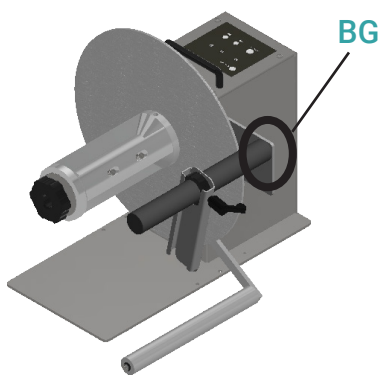

FIG. 1

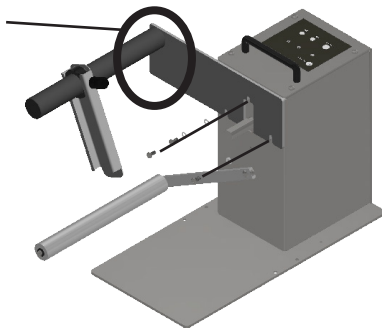

FIG. 2

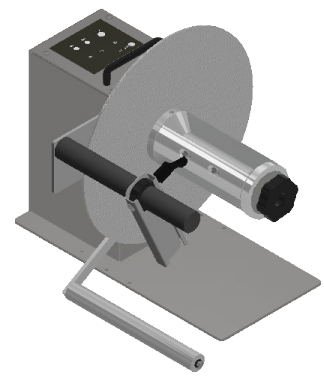

FIG. 3

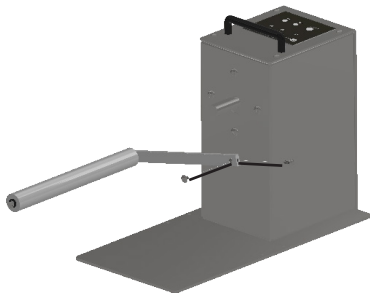

FIG. 4

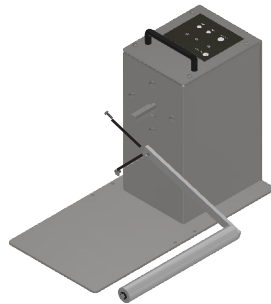

FIG. 5

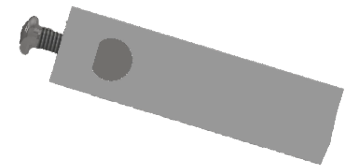

FIG. 6

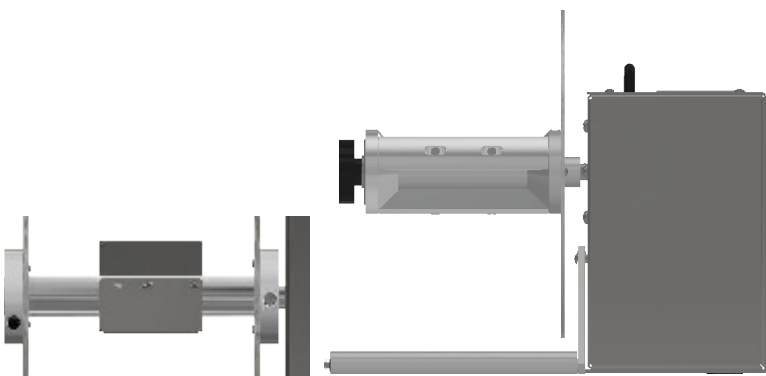

FIG. 7

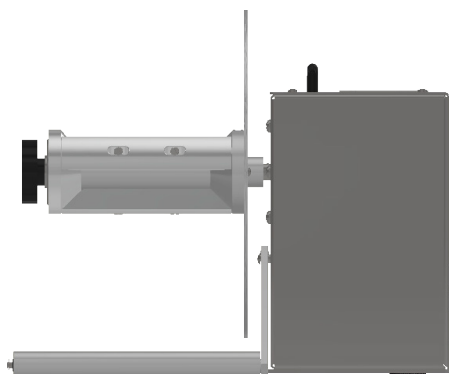

FIG. 8

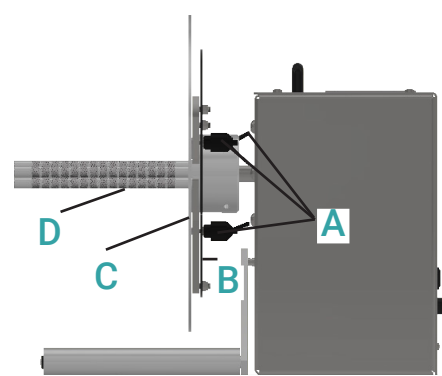

FIG. 9

REWINDING & UNWINDING, RIGHT ARROW CONFIGURATIONS

FIG. 10

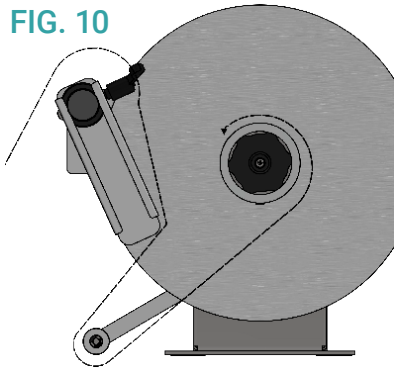

FIG. 11

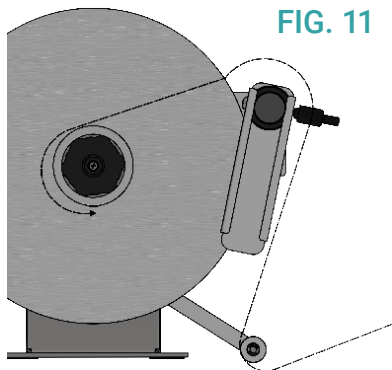

FIG. 12

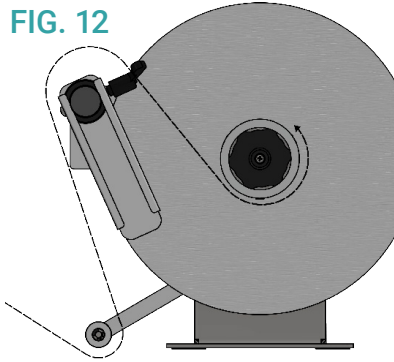
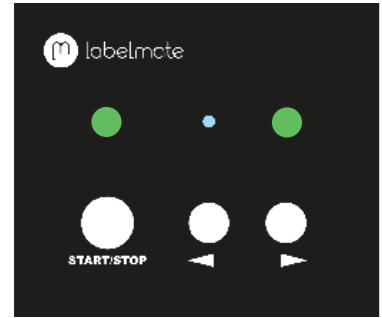
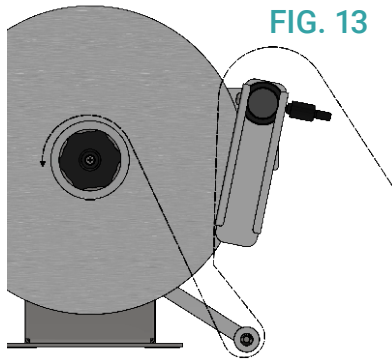

FIG. 13



REWINDING & UNWINDING, LEFT ARROW CONFIGURATIONS

FIG. 14

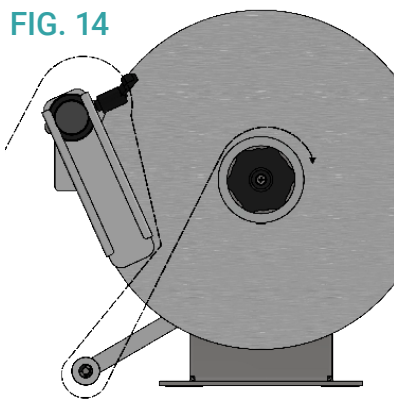

FIG. 15

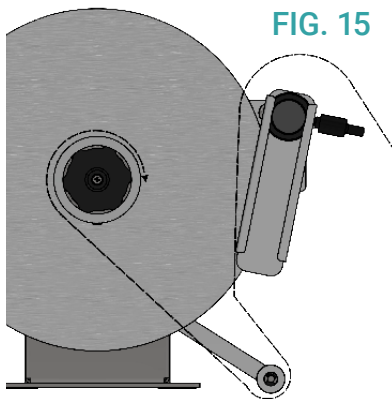

FIG. 16

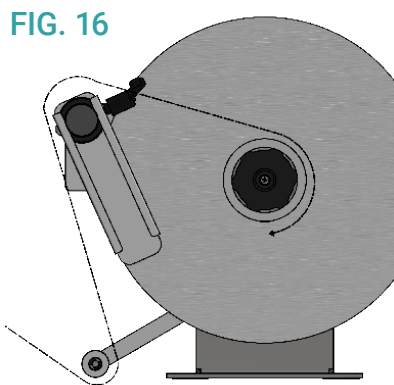
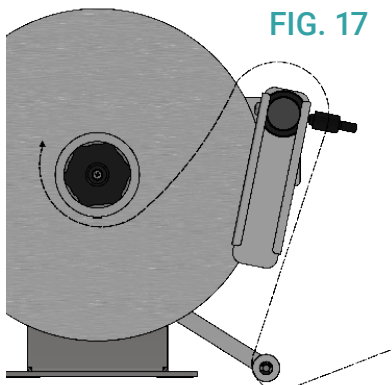

FIG. 17



Uni-Cat

The new UNI-CAT is the smartest and most “UNI-VERSATILE” rewinder/unwinder in the Labelmate product range ! With various core sizes, label widths, roll diameters and options to choose from, there is a rewinder/unwinder to fit any job you may have.

GENERAL CONTENT OF THE PACKAGING

- User Manual (this document)
- UNI-CAT Drive Unit
- Power Supply: INPUT 100-240V- 50-60Hz, Output 15V DC-4,33A
- Tension Arm with setscrew and Shaft Screw
- BRACKET GUIDE KIT

MODEL SPECIFIC CONTENT OF THE PACKAGING

- Model -“Quick-Chuck”™ Quick-Locking Core Chuck, with inner flange
- Model-“Standard” Shaft with three (3) metal Vanes installed, with inner flange
- Model-“10-INCHES” Shaft with six (6) metal Vanes installed, with inner flange
- Model-“1-INCH” Shaft with one (1) metal Vane installed, with inner flange
- Model-“ACH”: Adjustable Core Holder, fully assembled

MANUAL VALID FOR FOLLOWING PRODUCTS:

P/N	MODEL	DESCRIPTION	MAX LABEL WIDTH	MAX ROLL DIAM	MAX WEIGHT
LMR042	UNI-CAT-STANDARD	Standard for 76mm cores (38/40/44/50/70/100mm available) W x D x H:300 x 350 x 320 mm	155 mm	300 mm	8 KG
LMR043	UNI-CAT-ACH	Adjustable Core Holder for using any core diameter between 25 & 101 mm. W x D x H:280 x 310 x 310 mm	155 mm	280 mm	7 KG
LMR044	UNI-CAT-CHUCK	Easy-Loading Quick-Chuck for 76mm cores (38/40/44/70/100mm available) W x D x H:300 x 385 x 320 mm	170 mm (optional 220 & 270)	300 mm	10 KG
LMR045	UNI-CAT-10-INCHES	Standard for 76mm cores (38/40/44/50/70/100mm available) W x D x H:300 x 455 x 320 mm	255 mm	300 mm	10 KG
LMR046	UNI-CAT-1-INCH	For 25,4mm cores W x D x H:220 x 350 x 280 mm	155 mm	220 mm	8 KG

IMPORTANT INFORMATION / SAFETY INSTRUCTIONS

- this product is a label rewinder/unwinder. It is only to be used to rewind or unwind labels of the recommended dimensions and weight in an indoor, dry environment
- unplug the device before any manipulation
- use on a flat surface and/or fix the device using the holes in the base plate
- do not leave the power cable in a passageway and ensure sufficient ambient light in the working area
- the rewinder can be used in ambient temperatures of +2°C to 40°C
- connection of the machine to the power source must respect local legislations

STEP 1: INSTALL THE BRACKET GUIDE

- The Bracket Guide(BG) is mounted on the Right side for labels with a path going from Right to Left (FIG.11)
- The Bracket Guide is mounted on the Left side for labels with a path going from Left to Right (FIG.10)
- Loosen (but leaving in the chassis to avoid loss) the 3 upper screws on the chassis and slide the BG in between the screws and chassis as shown in FIG.1 and FIG.2
- Install the black shaft and glide the media guide over the shaft (FIG.3)

STEP 2: INSTALL THE TENSION ARM

- The Tension Arm can be mounted right or left, depending on the printer position (FIG.4 & FIG.5), but always on the same side as the Bracket Guide
- Remove and keep the large Screw from the end of the Tension Arm Shaft (Shaft below the main Motor Shaft).
- Loosen the Set Screw at the end of the Tension Arm and position the Arm with the Set Screw facing the flat on the Tension/Control Arm Shaft.
- Tighten the Set Screw facing the flat on the Shaft (FIG.6)
- Re-insert and tighten the Tension Arm Shaft Screw into the Tension Arm Shaft.

STEP 3: INSTALL THE TAKE-UP SHAFT

- STANDARD, 1-INCH AND 10-INCH(FIG.7): Slide the Flange Plate onto the hollow end of the Rewind Shaft. For maximum width, the Flange face should be flush with the end of the Shaft. Tighten the screw in the Hub.
- CHUCK (FIG.8): Mount the inner Flange onto the Quick-Chuck with two screws provided.
- Slide the Shaft and Flange Assembly onto the UNI-CAT Motor Shaft allowing for clearance to the Chassis and Motor Screws. Tighten the Allen Screw onto the flat part of the Motor Shaft until it is tight.
- ACH (FIG.9): Slide the Hub of the ACH over the motor Shaft of the UNI-CAT. Position the Hub so there is a gap between the ACH Hub and the Rewinder Drive Unit case. Tighten the Allen Screw onto the flat part of the Motor Shaft until it is tight.
- Set the UNI-CAT in place near the label exit slot of the printer
- Plug the Power Supply in a suitable power outlet and connect the UNI-CAT which is now ready for use

USING THE ACH (FIG.9)

- Loosen the three (A) Lock Levers on the back of the ACH Flange Plate (B)
- Grasp the front Flange Plate (C) with one hand and the rear Flange Plate (B) with the other.
- Rotate the Plates in opposite directions until the three Core Fingers (D) move to the center of the ACH next to each other.
- Slide an empty cardboard core only partway over the Fingers (D) leave about 50mm between the flange and the core.
- Now rotate the Flange plates in opposite directions to expand the Fingers against the inside of the cardboard core. While you hold the Flanges so the Fingers are against the inside of the core, rotate one of the Locking Levers clockwise until it is fixed. DO NOT OVER TIGHTEN.
- Move the other two (2) Locking Levers to the LOCK position. DO NOT OVER TIGHTEN.
- Now slide the core all the way on up against the inside Flange. If the core is too tight, loosen the Lock Levers and try again sliding the core a little further over the Fingers to yield less tightness.

REWINDING LABELS

- Switch the power off
- Slide an empty label core over the Quick-Chuck or Vanes on the shaft until the core is against the inner Flange Plate. On the Quick-Chuck, tighten the Lock Knob (for the ACH please read instructions above)

LABELS EXTERNAL

- Feed the label web from the printer over the black shaft, go under the Tension Arm and secure it to the take-up roll core with tape. Rotate the take-up reel a couple of turns. FIG.13 and FIG.16 show the paper path for standard rewinding, labels external. This paper path will provide the best and most tight finished label rolls.
- Depending on your printer type (height of the output) it might be more suitable to guide the paper first under the Tension Arm and then over the black shaft as shown in FIG.11 and FIG.14
- The UNI-CAT will select standard the correct, right direction arrow based on the position from the Tension Arm. Do not change the direction.
- Push the START/STOP button. The UNI-CAT will now go automatically to its AUTO-START position. LED INDICATOR START/STOP should be active together with 1 of the direction LED INDICATORS

LABELS INTERNAL

- Feed the label web from the printer over the black shaft, go under the Tension Arm and secure it to the take-up roll core with tape. Rotate the take-up reel a couple of turns. FIG.10 and FIG.15 show the paper path for rewinding, labels internal.
- Depending on your printer type, it might be more suitable to guide the paper first under the Tension Arm and then over the black shaft as shown in FIG.12 and FIG.17
- IMPORTANT: **Now change to the opposite direction arrow** as the one that is activated standard and push the START/STOP button. The UNI-CAT will now go automatically to its AUTO-START position. LED INDICATOR START/STOP should be active together with 1 of the direction LED INDICATORS.

UNWINDING LABELS

- Operate the UNI-CAT in the same way as described above for rewinding.

The English text is the original instruction. Other languages are translations of the original instructions.

AT LABELMATE, SAFETY IS OUR NUMBER ONE PRIORITY. THE FOLLOWING INFORMATION PROVIDES GUIDELINES FOR SAFETY WHEN USING LABELMATE EQUIPMENT.

Any piece of machinery can become dangerous to personnel when improperly operated or poorly maintained.

All employees operating and maintaining Labelmate equipment should be familiar with its operation and should be thoroughly trained and instructed on safety.

Most accidents are preventable through safety awareness.

Every effort has been made to engineer safety into the design of Labelmate equipment per standards set forth by ANSI and others that apply as necessary. Areas of potential danger are mechanically and/or electrically protected. Safety labels and instructional decals are visible to the operator and located near any potential hazard.

TRAINING AND INSTRUCTION

It is the responsibility of the customer to ensure that all personnel who will be expected to operate or maintain the equipment participate in training and instruction sessions and become trained operators. All personnel operating, inspecting, servicing or cleaning this equipment must be properly trained in operation and machine safety. BEFORE operating this equipment, read the operating instructions in the manual.

GENERAL SAFETY

- Ensure that all power sources are turned off when the machine is not in use. This includes electrical power.
- Read the manual for any special operational instructions for each piece of equipment. The Labelmate product manual is included in the product packaging and can be found on the website www.labelmate.com
- Know how the equipment functions and understand the operating processes.
- Know how to shut down the equipment.
- Understand the equipment safety labels
- Wear the appropriate personal protective equipment for the job to be performed (EX: eye protection, gloves, safety shoes, etc.). Ensure that nothing you are wearing could get caught in the machinery.
- When working on or around all equipment, avoid wearing loose clothing, jewelry, unrestrained long hair, or any loose ties, belts, scarves or articles that may be caught in moving parts. Keep all extremities away from moving parts. Entanglement can cause death or severe injury.
- For new equipment, check plant voltage with the voltage specified on the machine. Electrical specifications for your machine are printed on the machine serial number tag. A properly grounded electrical receptacle is required for safe operation regardless of voltage requirements.
- Use the equipment only for its intended purpose.
- Keep the operating zone free of obstacles that could cause a person to trip or fall toward an operating machine. Keep fingers, hands or any part of the body out of the machine and away from moving parts when the machine is operating.
- Any machine with moving parts and/or electrical components can be potentially dangerous no matter how many safety features it contains. Stay alert and think clearly while operating or servicing the equipment. Be aware of operations and personnel in your surroundings. Be attentive to indicator lights and/or operator interface screens displayed on the machine and know how to respond.
- Do not operate machinery if you are fatigued, emotionally distressed or under the influence of drugs or alcohol.
- Know where the FIRST AID SAFETY STATION is located.
- Rotating and moving parts are dangerous. Keep clear of the operating area. Never put any foreign object into the operating area.
- Use proper lifting and transporting devices for heavy equipment. Some types of equipment can be extremely heavy. An appropriate lifting device should be used.



+32 2 375 69 60

brussels@labelmate.com

Bergensesteenweg 78
1651 Lot (Belgium)

www.labelmate.com